

BayPort™ p40

NP/TM Evaluation System



Product Brief

Advance Information

PRODUCT HIGHLIGHTS

- ❑ High performance 40G evaluation platform for Bay's Internetworking Processor family - Chesapeake™
- ❑ Enhance productivity with a simplified and futuristic programming model.
- ❑ Highly integrated data/control plane allowing service providers to rapidly prototype and validate network services.

Introduction

With many network equipment designs increasingly becoming dependent on packet processing, validating the functionality and performance of network processors becomes critical to the product's success. BayPort™ is a comprehensive demonstration and evaluation platform for Bay Microsystems' Internetworking Processor™ family of network processor (NP) and traffic management (TM) products, enabling customers to rapidly develop and deliver next generation systems.

BayPort p40 features Bay's protocol agile Chesapeake™ products. Chesapeake is the world's first programmable 40G Network Processor and Traffic Manager. Chesapeake's combined NP/TM functions deliver an astonishing 122 million packets/sec performance while guaranteeing 40G line-rate. Chesapeake is targeted at system configurations ranging from high density 1G and 10G Metro Ethernet aggregation boxes to carrier grade 20G and 40G system solutions.

BayPort p40

BayPort is a demonstration and evaluation platform based on mid-plane ATCA architecture. The system is designed to include Chesapeake-based primary card and dual mezzanine connectors. The primary card includes Chesapeake subsystem to support the full feature set of Chesapeake including classification, editing, policing, traffic management, multicast and forwarding of packets/data that enables sophisticated services to be delivered at line rate.

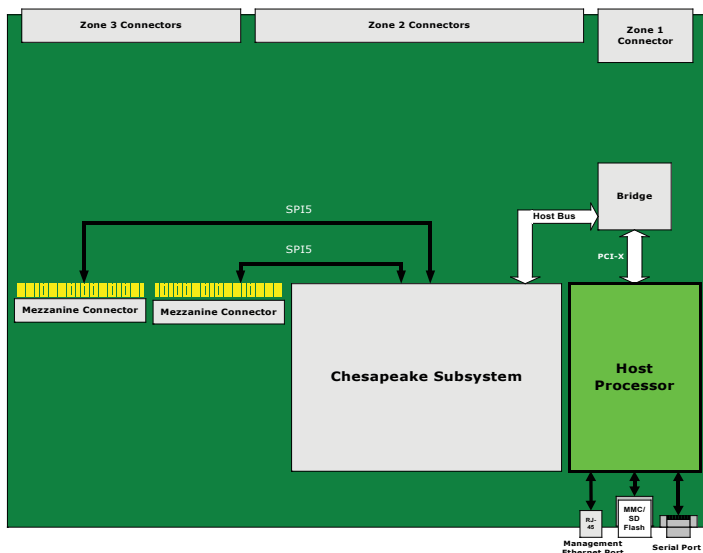

Chesapeake-Based Primary card

Physical Characteristics

- ❑ ATCA compatible 19 inch rack mountable form factor
- ❑ 80-250VAC and -48VDC power supply options
- ❑ Mid-plane chassis design
- ❑ Modular and interchangeable network interface and preprocessing cards:
 - 40G Multi-port Ethernet Interface Card supporting 12x1GE, 2x10GE, 2xSPI 4.2 interfaces
 - Mezzanine Interface Cards supporting the following interfaces:
 - 10x1GE
 - 1x10GE
 - 4xOC48
 - 1xOC192
- ❑ Processor PCI Mezzanine Card (PPMC)
 - PowerPC based host processor
 - Up to 2GB DDR SDRAM with ECC
 - User Flash memory
 - PCI bridge/controller

Product Features

- ❑ Bay-powered 40G Universal NP/TM Card for switching, interworking and aggregation of packets and cells with the following capabilities:
 - Any-to-any agile, line-rate protocol mediation
 - Datagram processing
 - Network policing & traffic management
 - Deep-classification tunneling and editing
 - Multicast support
 - PWE3, IP Fragmentation support
- ❑ Access to statistics, status and control functionality
- ❑ Indicator LEDs for power, faults, link, activity
- ❑ Management via CLI or WEB interface
- ❑ NEXTware software suite running on host processor
- ❑ Linux OS
- ❑ Hardware support for management interfaces:
 - Local Craft access
 - Ethernet for telnet and CLI
 - Network HTTP

40G Multi-port Ethernet I/F Card

BayPort p40 platform supports multiple interface configurations to address pizza box to chassis based applications. The platform is offered with a standard interface card which supports 12x1GE line interfaces and 2x10GE uplink ports. The full feature set of Chesapeake can be verified using this configuration. In addition, the interface card also supports 2xSPI4.2 interfaces which can be used to interface with external switch fabric devices or other line interfaces. This enables customers to verify interworking of Chesapeake with any standard or proprietary devices.

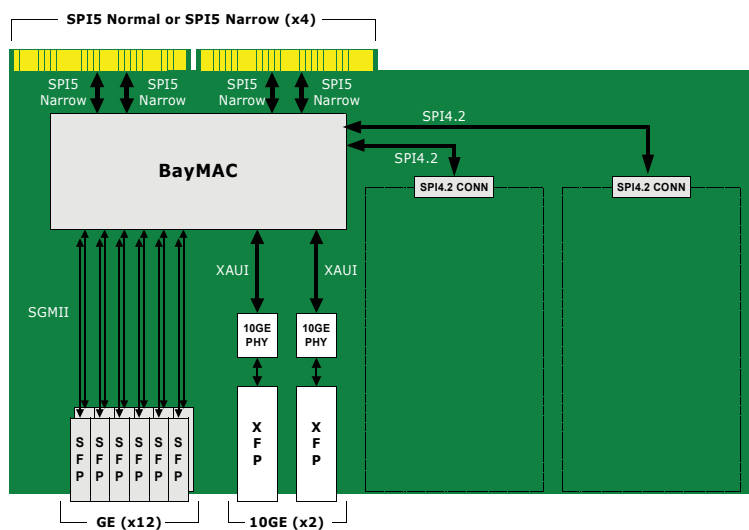

Chesapeake-Based Standard I/F Card

BayMAC - SPI 5 interface devices

BayPort supports BayMAC devices which represent a family of enhanced Ethernet MAC/OIF-SPI-4.2 devices that provide complete 1:1 and 2:1 oversubscription connectivity to 10Gbps (OIF-SPI-5 narrow) and 40Gbps (OIF-SPI-5 normal) systems interfaces. This family of devices is targeted at supporting enterprise and metro-Ethernet applications which require interfacing to network processing elements, such as Chesapeake. The MACs are IEEE 802.3 compliant media access controllers with enhanced channelization, oversubscription QoS, and packet memory. SPI-4.2 interfaces allow for mixing 10Gbps standard devices to multiplex onto the 40Gbps systems-side bus.

NEXTware™ – Bay’s Highly Simplified Programming Model

Using BayPort, developers can experience the ease of programming and configuration provided by Bay’s NEXTware™ software suite with its powerful Applications Programmers Interface (API). NEXTware provides a seamless and straightforward programming interface to the versatile features and performance of Bay’s Internetworking Processors, and a simple API interface to existing control plane software development environments. BayPort provides the flexibility to configure the box both at the system and network processor level. This includes smart device initiators and configurators which can be triggered by the end-user to seamlessly configure and edit memory, physical interfaces, traffic parameters, etc. The platform comes with a library of application modules and comprehensive diagnostics to jump start software development.

The capabilities provided by BayPort and NEXTware can be used to support a wide range of features and protocols ranging from Layer 2 to Layer 4 including (but not limited to):

- Ethernet: Port mirroring, MAC learning and aging, MAC switching, MAC filtering, VLAN switching, spanning tree
- IPv4/IPv6: ACL filtering, switching and forwarding, tunnel resolution, routing
- MPLS: Switching, L2 VPN, LER

BayPort Target Applications

The deterministic nature and scalability of Bay Microsystems’ Internetworking Processor family of NP/TM products enables customers to develop network equipment targeting a range of applications at very low risk. These include:

- Carrier Ethernet switching and transport
- Ethernet LAN extension over ATM, POS or Ethernet
- Aggregation of Gigabit Ethernet, IP, ATM, POS
- Packet Service Provisioning Platform (PSPP)
- PON aggregation
- Multiservice Provisioning Platform (MSPP)
- BRAS, IP-DSLAM or similar access systems

Corporate Headquarters
2055 Gateway Place, Suite 650
San Jose, CA 95110
T 408 437 0400
F 408 437 0410
E info@baymicrosystems.com
www.baymicrosystems.com

Some features listed in the specifications are under development.

© Bay Microsystems 2006. All rights reserved. Bay Microsystems, the Bay Microsystems logo, BayPort, Biscayne, Internetworking Processor, Montego, NEXTware, ‘The Network is the Experience’ are all trademarks and/or registered trademarks of Bay Microsystems, Inc. Any other trademarks are the property of their respective owners.

