

# IBEx G40/M40

## Global InfiniBand Extension Switch/Router

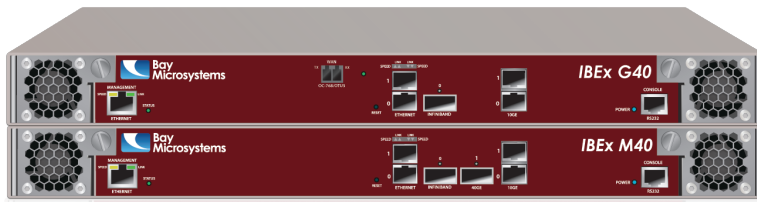

As commercial enterprises and government agencies strive to reduce expenses, increase reliability, and expand services, they are realizing that using separate application-specific networks and dedicated isolated data centers requires more equipment, power, management personnel, training, and maintenance resources than using a common, converged network infrastructure with consolidated storage and server resources. While there are numerous interconnect technologies to choose from for migrating to a converged data center network infrastructure, picking one that will scale with your business needs and is also commercially viable is critical.

When you seriously consider the attributes of future scalability and commercial viability, the choices of interconnect technology narrow to one, InfiniBand. As a result, InfiniBand is quickly becoming the preferred technology for connecting high performance computing and mass storage resources in a converged data center network infrastructure. InfiniBand's industry standard ecosystem, which includes cost effective commodity hardware, open source software solutions, proven reliability, and the ability to scale seamlessly as performance increases, has made InfiniBand the fastest growing interconnect technology within this market segment.

Deployed in thousands of production environments throughout the world, InfiniBand combines high-speed data movement between systems with ultra-low latencies, reduced power consumption, and 100-percent reliability to support highly scalable computing and storage over a single converged fabric. InfiniBand supports up to 120 Gigabit interfaces today with an unprecedented industry-backed roadmap to deliver higher bandwidths as future business demands.

---

## HIGHLIGHTS

---

### *Global InfiniBand Extension Switch/Router Capabilities:*

- *Extends 4X InfiniBand QDR (up to 40 Gbps) at line rate to any point on the globe*
- *Enables seamless InfiniBand extension over standard optical transport and packet switched networks*
- *Provides flexible InfiniBand switching and routing capabilities all within a compact, low-power platform*
- *Supports encapsulation of 1/10G Ethernet over the wide area network enabling site-to-site management traffic*

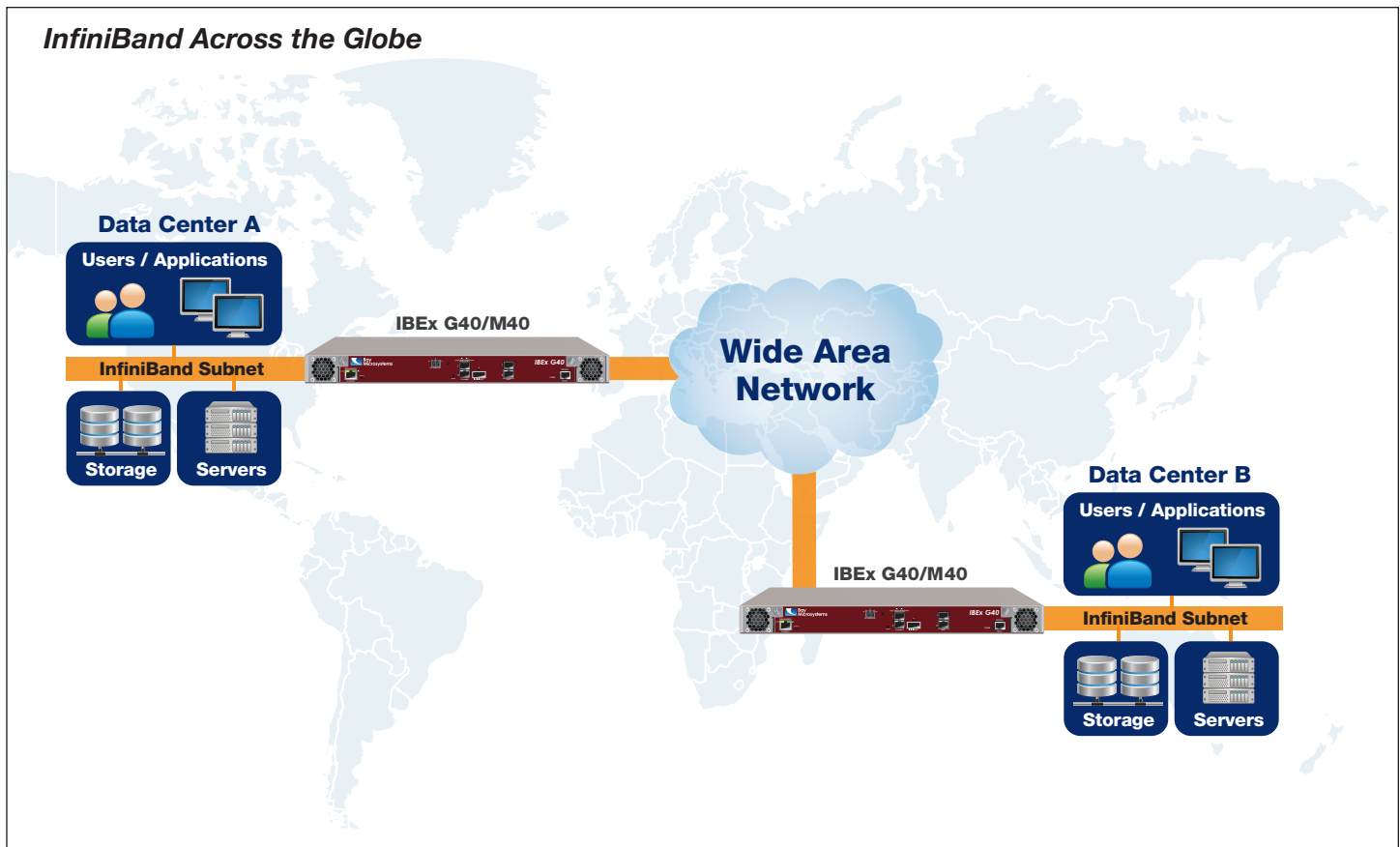

## Architecture Challenges

In conjunction with InfiniBand's capability to successfully support a converged data center network infrastructure, the introduction of commercially available I/O, storage, and server virtualization applications has been instrumental in making data center consolidation initiatives very pragmatic for commercial enterprises and government agencies. These initiatives have been so successful that a new rapidly growing trend is starting to appear in the marketplace: the desire to extend InfiniBand over campus, metro, and wide area network connections to support disaster recovery, multi-site failover, and real-time global data access.

While InfiniBand provides many benefits within the data center, the challenge has been how to use InfiniBand for linking together geographically isolated data centers to form a single unified network infrastructure for sharing compute and storage resources. Until now, InfiniBand's inherent distance limitations due to inadequate port buffering have made it unsuitable for deployment between multiple geographically distributed sites.

## The Solution

The IBEx G40/M40 platforms utilize Bay Microsystems' proprietary packet and transport processing technology along

with enhanced credit buffering and end-to-end flow control to reliably extend native InfiniBand over campus, metro, and wide area networks spanning from just a few miles to thousands of miles.

This allows the IBEx platform to provide InfiniBand range extension over a variety of network infrastructures enabling IT managers to maintain protocol continuity beyond a single site to virtually anywhere around the globe without the need to modify existing applications or the local InfiniBand network.

## Applications

The IBEx G40/M40 platforms are designed to work with a broad range of applications allowing InfiniBand compute and storage resources to be shared between data centers.

This includes:

- Global file systems and storage architectures
- High performance computing and visualization
- Low latency trading and market data feeds with disaster recovery
- Multi-site clustered databases and data warehousing
- Distributed healthcare and medical imaging applications

## The System

The IBEx G40/M40 provides flexible connectivity options delivering line rate 4X InfiniBand QDR (up to 40 Gbps) performance over standard optical transport and packet switched networks. This allows IBEx to seamlessly transport native InfiniBand over most wide area network technologies including 40G Ethernet, IPv4/IPv6, SONET OC-768/SDH STM-256, ITU-T G.709 OTU3, and dark fiber. In addition to InfiniBand, the IBEx also supports encapsulation of 1/10G Ethernet links over the same wide area network connection allowing management and other network traffic to transparently pass without the need for additional wide area network services between sites.

IBEx supports two basic modes of operation: switching and routing. In switch mode, the systems appear as two 2-port switches capable of connecting remote data centers by merging independent subnets into a single unified InfiniBand infrastructure for all application and network services. In router mode, the IBEx systems appear as two 2-port routers providing physical isolation between data centers allowing each InfiniBand subnet to be independently managed while seamlessly routing all application and storage traffic between subnets.

## Compatibility & Performance

The IBEx G40/M40 is designed to work with all native InfiniBand protocols allowing applications to maintain high performance Remote Direct Memory Access (RDMA) transfers between data centers providing near line rate performance over thousands of miles. Although optical latencies over distance cannot be avoided, the IBEx platform is fully optimized to provide efficient, uninterrupted cut-through data transfer of InfiniBand packets without introducing any noticeable latency that could degrade application performance.

The IBEx even supports InfiniBand's built-in virtual lane functionality providing complete quality of service control for application and storage traffic by allowing packets to be isolated into separate data queues using standard service level associations. With support for up to four operational (data) and one management virtual lanes, the IBEx can maintain all virtual lane associations across the wide area network thus preserving end-to-end traffic flow control for all InfiniBand applications and services.

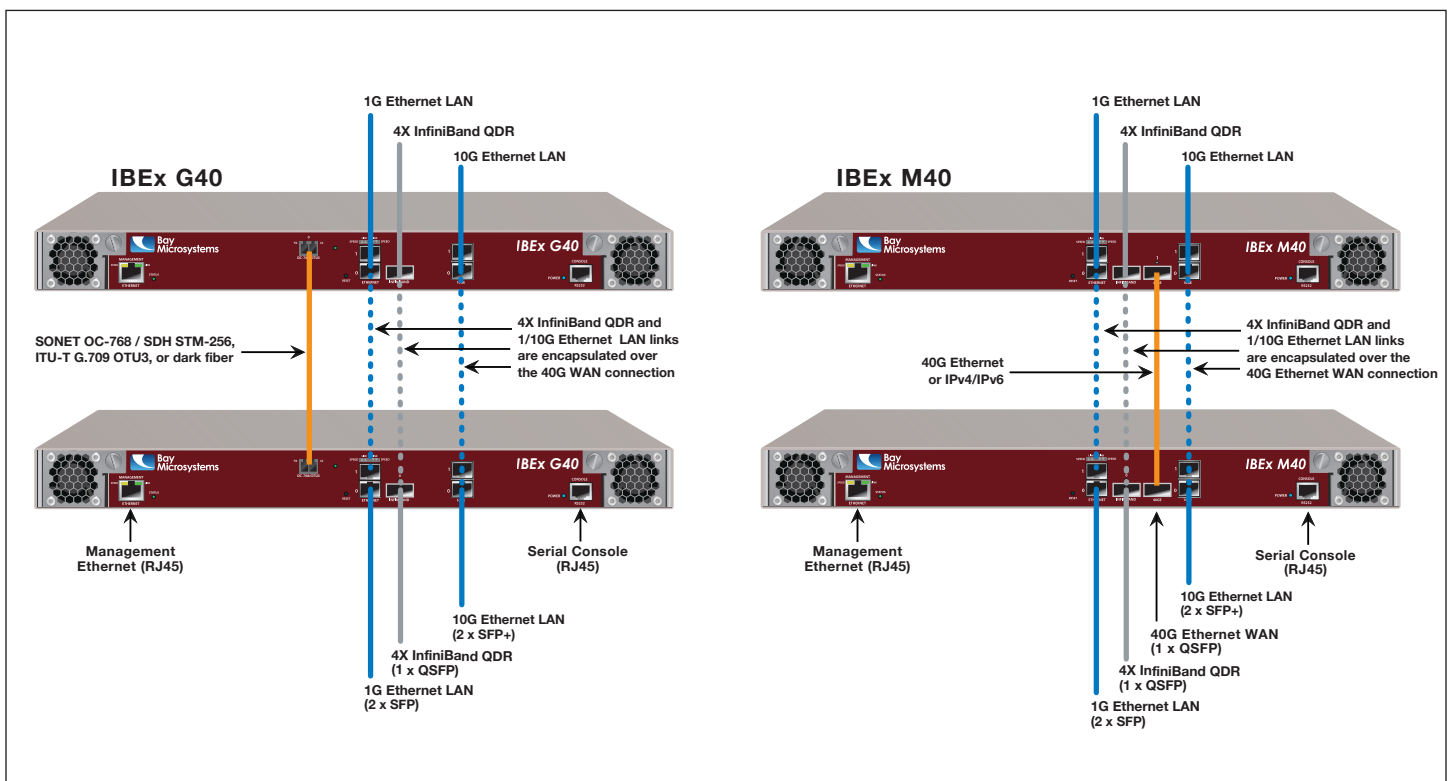

## SPECIFICATIONS

**Chassis**

Form Factor	1U, 19-inch standard rack mount
Dimensions	17.26" Width x 19.40" Depth x 1.72" Height (43.85 cm x 49.27 cm x 4.36 cm)
Weight	Fully configured, 21.0 lbs. (9.53 kg)
Ventilation	Forced air system with front-to-back airflow (Reverse airflow option also available)
Acoustics	Intelligent, speed-controlled fans for low-noise operation
Indicators	AC power input, system status, and link/activity LEDs
High Availability	Redundant, hot-swappable AC power supplies and fan trays
Warranty	2 Years for Hardware and 1 Year for Software

**Power and Environmental**

Power Input	90-264 VAC (47-63Hz), auto-voltage sensing
Power Supplies	2 x 600 Watts, dual AC input
Power Consumption	140 Watts (G40) / 110 Watts (M40)
Temperature	Operating: 32°F to 104°F (0°C to 40°C) Storage: -40°F to 158°F (-40°C to 70°C)
Humidity	10% to 95% RH, non-condensing

**Management and Monitoring**

Ethernet	1 x RJ45 (Full Duplex 10/100/1000Base-T w/auto MDI-X)
Serial	1 x RJ45 (RS-232)
Protocols	HTTP/HTTPS, Secure Shell (SSH), Telnet, Network Time Protocol (NTP; RFC 1305)
User Interface	Web-based Graphical User Interface (GUI), Command-Line interface (CLI)
User Authentication	Supports multiple user accounts and privilege levels
Remote Monitoring	SNMP (v2/3) managed object support, syslog

**InfiniBand Interface**

Node Type	2-port switch or router
Interface	1 x 40G Quad Small Form-factor Pluggable (QSFP)
Port Type	InfiniBand Architecture (IBA) 1.2 Compliant
Physical Layer	4X InfiniBand SDR/DDR/QDR (up to 40Gbps)
MTU Size	Up to 4096 bytes
Virtual Lanes	4 Operational (VL0-3), 1 Management (VL15)
WAN Monitoring	Presented as a virtual InfiniBand port
Port-to-Port Latency	1.9µs (G40), 0.8µs (M40)
Buffering Capacity	9,230 mi (15,000 km)

**40G WAN Interface (G40 only)**

Node Type	Host
Interface	1 x 40G 300-pin MSA transponder (factory installed) LC fiber connector
Port Type	LC fiber connector
Physical Layer	SONET OC-768/SDH STM-256 or ITU-T G.709 OTU3
Modulation	NRZ (VSR2000-3R2) or NRZ-DPSK (DWDM Tunable) (optional)
Payload	Packet over SONET (PoS), GFP-F
Timing	Integrated stratum reference or BITS line timing

**40G Ethernet Interface (M40 only)**

Node Type	Host
Interface	1 x 40G Quad Small Form-factor Pluggable (QSFP)
Port Type	MPO or LC fiber connector
Physical Layer	40GBASE-CR4/SR4/LR4
Payload	IPv4/IPv6, MPLS

**10G Ethernet Interface**

Node Type	Virtual wire
Interface	2 x 10G SFP+ pluggable transceiver
Port Type	LC fiber connector
Physical Layer	10GBASE-SR/LR/ER/ZR
MTU Size	Up to 9600 bytes

**1G Ethernet Interface**

Node Type	Virtual wire
Interface	2 x 1G SFP pluggable transceiver
Port Type	RJ45 or LC fiber connector
Physical Layer	1000BASE-T/SX/LX
MTU Size	Up to 9600 bytes

**IBEx Models**

G40	1-15,000km range over SONET OC-768 / SDH STM-256 or ITU-T G.709 OTU3
M40	1-15,000km range over 40G Ethernet or IPv4/IPv6

**Corporate Headquarters**

2055 Gateway Place, Suite 650, San Jose, CA 95110  
Tel 408 437 0400 | Fax 408 437 0410  
info@baymicrosystems.com | www.baymicrosystems.com

**Contacts**

For additional information or sales inquiries please contact:  
**sales@baymicrosystems.com**

Some features listed in the specifications may be under development.

© Bay Microsystems, Inc. 2012. All rights reserved. Bay Microsystems, the Bay Microsystems logo, are all trademarks and/or registered trademarks of Bay Microsystems, Inc. Any other trademarks are the property of their respective owners.

Doc ID: 16-0145-001 Rev. D